

**Rotary vane air
compressors for industry**

© **hydrovane**

Industry's advantage with Hydrovane



www.hydrovaneproducts.com



© hydrovane

Rotary Vane Air Compressors

The right compressor for your business

Versatile

Open and enclosed format packages and air end options

- 50 / 60 Hz
- 6 - 10 bar
- 0.1 - 7.5 m³/min
- 4 - 264 cfm

Quiet as standard

With noise levels as low as 62 dB(A) a Hydrovane can be located at the point of use.

Fixed and Regulated speed models

Matching air demand with your business needs.

Reliable by Design

Direct drive

No gears. No belts. Up to 100,000+ operating hours due to its simple integral design.

High quality air

Clean, dry and pulse free straight from the outlet means less downstream equipment required.

Slow speed

1450 - 1760 rpm speed operation results in low noise, low stresses and long life.

Common replacement parts

Quick, cost-effective servicing, with minimal downtime.



Powerful and Cost Effective

Hydrovane Pro Controller

For total electronic control, greater connectivity and flexibility.

Regulated speed

Proven, simple and long-lasting technology solutions delivering up to 50% energy savings.

Reduced Energy Venting System (REVS)

Reducing off-load power to as low as 20%.

Air Intake modulation control

No wasteful overproduction of air.

Guaranteed

Market leading warranty

Up to 10 years or 48,000 operating hours is now available for total peace of mind on all standard Hydrovane models.

Distributor support

Hydrovane machines are supplied and maintained by a wide network of Authorised Distributors and highly skilled, factory-trained service engineers.

A range of compressors

From stand-alone...

Open - Fixed Speed

Small and compact, Hydrovane HV01 - HV04 models are ideally suited for light industrial and workshop applications where the compressed air outlet needs to be situated close to the point of use.

HV01 - HV04 Models

Tripod or Receiver mounted

- 50 / 60 Hz
- 1.1 - 4 kW
- 10 bar
- 0.1 - 0.6 m³/min
- 4 - 20 cfm



Enclosed - Fixed Speed and Regulated Speed (RS)

Taking components that have been developed specifically with energy-saving in mind, Hydrovane's designers and engineers have developed a rotary vane compressor for the twenty first century, whilst retaining the features which have helped build Hydrovane's reputation for quality and reliability around the world.

HR04 - HR07RS Models

Fully Enclosed

- 50 / 60 Hz
- 4 - 7.5 kW
- 7 - 10 bar
- 0.6 - 1.3 m³/min
- 20 - 46 cfm





Whilst all Hydrovane rotary vane compressors are designed and built with the highest levels of efficiency in mind, if you're looking for the ultimate in energy-saving technology, we offer our 7.5 to 45 kW machines with a Regulated Speed (RS) option.

RS machines optimise energy efficiency when operated below full load capacity. This can deliver benefits of up to 50% energy savings compared to the equivalent standard fixed speed model.

HV11 - HV45RS Models

Fully Enclosed

- 50 / 60 Hz
- 11 - 45 kW
- 6 - 10 bar
- 1.3 - 7.5 m³/min
- 46 - 264 cfm



...to the complete compressed air solution

Complete packages save space. Save time.

Hydrovane compressors are available as fully integrated packages. Hypacs are available with membrane or refrigerant dryers and integrated receivers and come as a factory built package or can be supplied as a kit for local assembly.

Integrated packages can be more cost- effective than building a system using separate components.

Hydrovane's knowledgeable Authorised Distributors can advise you on the best package for your business to make the most of factory space and give you more for your budget.

Hypac Open - Fixed Speed

HV01 - HV04 Models

Receiver Mounted

- Integrated Membrane Dryer
- 50 / 60 Hz
- 4 - 7.5 kW
- 10 bar
- 0.1 - 0.6 m³/min
- 4 - 20 cfm



Hypac Enclosed - Fixed Speed
and Regulated Speed (RS)

HR04 - HV22RS Models

Fully Enclosed

- Integrated Refrigerant Dryer model
- Integrated Receiver model
- 50 Hz
- 4 - 22 kW
- 7 - 10 bar
- 0.6 - 3.6 m³/min
- 20 - 127 cfm



Make your budget go further

Hydrovane Air Solution packages are the ultimate in convenience.

Fully packaged with integrated receivers, refrigerant dryers and filtration, Hydrovane Air Solution models offer you the best solution for your compressed air requirements.

©hydrovane
air
solution

Air Solution Enclosed - Fixed Speed
and Regulated Speed (RS)

HR04 - HV22RS Models

Fully Enclosed. Fully Packaged

- Complete Package
- Integrated Refrigerant Dryer
- Integrated Receiver
- Filter Pack
- 50 Hz
- 4 - 22 kW
- 6 - 10 bar
- 0.6 - 3.6 m³/min
- 20 - 127 cfm



At the heart of your
compressor's performance

Hydrovane Pro puts you in complete control

HR04 - HV45RS Models

Hydrovane Pro
Controller Features:

- Real Time Clock
- Timer Control
- Second Pressure Setting
- Status Display
- Group Fault Outputs
- Error Logs
- Digital Inputs
- MODBUS RTU
- Sequencer Capability
- Flash Programmable





with simple-to-use, intelligent electronics

All Hydrovane compressors in both Fixed and Regulated Speed in the 4 to 45 kW model range are fitted as standard with the Hydrovane Pro Electronic Controller. This control system ensures reliable operation and protects your investment by continuously monitoring the operational parameters of the compressor.

The Hydrovane Pro also has the capability to have programmable inputs and outputs for increased control of ancillary equipment.

It is now possible to simply connect a Hydrovane Pro controlled compressor to the range of Sequencer Technologies within the Gardner Denver group allowing flexibility of use and maximising energy reduction.

HV01, HV02 and HV04 Models Standard Starters

A high quality starter with a robust control circuit, including over-temperature protection.





Reduce your energy costs

How does a Hydrovane compressor save energy?

Regulated Speed (RS)

- RS control ensures optimum load conditions throughout the compressor's speed range

Delivering maximum efficiency

Air Intake Modulation

- Air intake modulation at minimum speed delivers further energy savings

To match the reducing air demand

Reduced Energy Venting System (REVS)

- In-built Reduced Energy Venting System (REVS)

Improved part-load and off-load performance

SMART SERVO energy reduction system

- Optimised motor, drive and air end

Proven air cooled inverter drive

High efficiency across a broad flow range

Substantial energy savings delivered.

Please contact your local authorised Hydrovane distributor for an Air System Energy Review and Data Logging.

Reduce the cost of ownership and minimise your energy consumption.

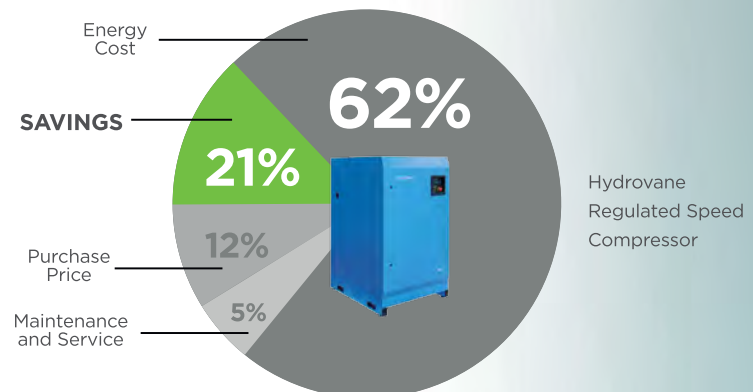
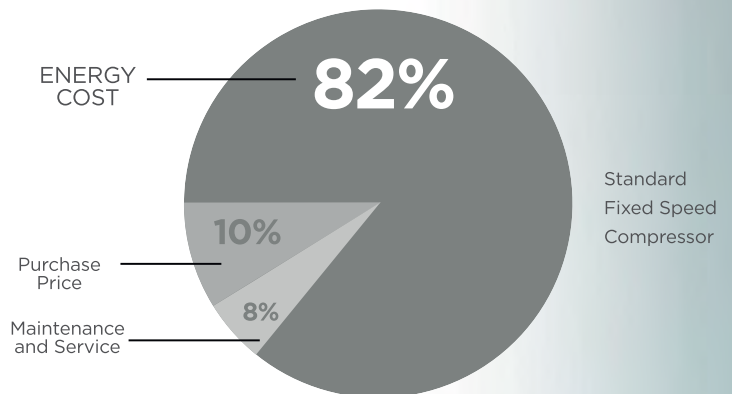



Customise your Hydrovane

to suit your applications

With Hydrovane's versatile rotary vane compressor technology, we can deliver the widest range of bespoke OEM solutions.

The possibilities are endless when it comes to supplying air for a specific application inside and outside the standard industrial arena. Hydrovane has over 50 years experience in supplying proven solutions to OEMs, either as air ends or complete packages, designed and purpose built. In addition, there are occasions when a customer may require a special build, and this is where Hydrovane can deliver custom solutions.

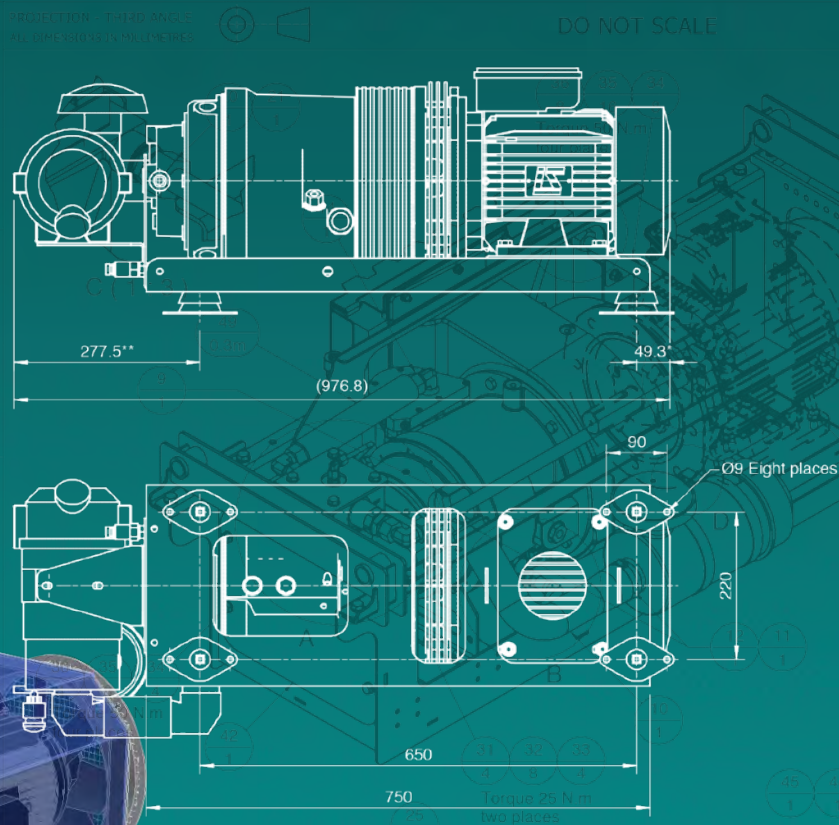
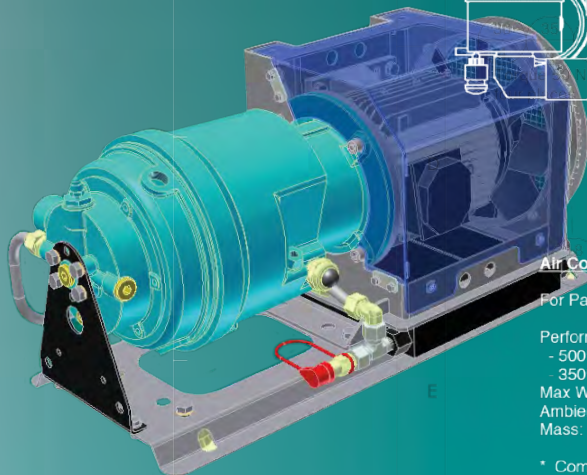

Air Cooled Compressor Arrangement

For Part Numbers refer to Drawing AV04-ATSN-xx

- Performance @ 1450 rpm:
 - 500* l/min @ 10 bar
 - 350* l/min @ 12 bar
- Max Working Pressure: 12 bar
- Ambient: 40°C max
- Mass: 75* kg (approximately)

* Compressor stator and motor type will be selected to suit specific flow/pressure requirements and ambient conditions. Motor dimensions/weight may vary.

** Inlet Air Cleaner can be supplied as a loose item or mounted on a bracket on the end of the frame. Air Inlet adapter can be rotated through 30° increments to suit the application

1

2

3

4

5

6

FINISH
MACHINING
UP TO 100
ONCE 30
PROVISIONAL
FROM 100
TYPICAL
CONCRETE
G13 100
MACHINING
RELOCATED
SHOWN THE
WALLS IN 4
ALL DIMS



Hydrovane Advance™10

Warranty that delivers complete peace of mind



Hydrovane standard warranty:

All Hydrovane compressors are guaranteed for 12 months from the date of installation providing the installation is approved by an authorised Hydrovane distributor and the correct service procedures and genuine service kits, parts and lubricants are used.

The Hydrovane Advance 10 extended warranty programme is a unique market leading compressor care package designed to deliver comprehensive warranty cover for up to 10 years or 48,000 operating hours on all Hydrovane compressor airends.

Key benefits

- ➔ Free
- ➔ Guaranteed Quality
- ➔ Accurate Maintenance Budgeting
- ➔ Maximise Compressor Life
- ➔ Simple administration
- ➔ Hydrovane will give you an appropriate service schedule
- ➔ Trained and qualified engineers will take care of your machines.

We're the professionals

Hydrovane's distributors will visit your site, free of charge, to assess your individual compressed air requirements in order to deliver the solution that best meets your requirements.

Your local **Hydrovane distributor**

Sales and Aftermarket Support. **Back-up you can trust**

Hydrovane service philosophy is one of regular maintenance being the key to long, reliable, trouble-free compressor life. Hydrovane offers extensive aftermarket support through an extensive network of Authorised Distributors who will provide:

FREE energy surveys

To test your compressed air system for possible leaks and other costly inefficiencies

Service Kits - Genuine OEM spare parts

The service kit concept has been developed to make our compressor servicing quick, easy and cost effective. Using the service kits as part of the recommended service schedule will prevent costly breakdowns, ensuring a continuous supply of high quality compressed air.

Lubricants - Approved for vane usage

Even the most reliable compressors in the world require routine lubricant changes to maintain peak performance. Over many years, Hydrovane has developed a range of high quality lubricants that have been specifically formulated to guarantee optimum compressor performance.

Factory-trained service engineers

Hydrovane is committed to providing every Hydrovane compressor owner with fully trained Service Engineers to care for their investment throughout our Global Distribution Network.



Look after your Hydrovane and it will last a lifetime

50 / 60 Hz Rotary Vane Air Compressors

Open - Fixed Speed



Motor Power (kW)	Model	Voltage/Phase		Starter Type	Configuration	Receiver Capacity (litres)	Maximum FAD m ³ /min (cfm)		Dimensions (mm)			Noise dB(A)	Air Quality (mg/m ³)
		50Hz	60Hz				10 bar	7 bar	Depth	Width	Height		
1.1	HV01	240V 1Ph 400V 3Ph	-	DOL	Tripod Mounted	-	0.12 (4.3)		270	700	470	62	<3
1.5	HV01	-	230V 1ph 230V 3ph 460V 1ph				0.14 (4.9)						
2.2	HV02	240V 1Ph 400V 3Ph	-				0.23 (8.0)						
1.1	HV01	240V 1Ph 400V 3Ph	-		Receiver Mounted	75	0.12 (4.3)		300	1120	730	62	
1.5	HV01	-	230V 1ph 230V 3ph 460V 1ph				0.14 (4.9)						
2.2	HV02	240V 1Ph 400V 3Ph	-				0.23 (8.0)						
4.0	HV04RM	400V 3Ph	-				200						
5.5	HR05PR	400V 3Ph	-	SD	Receiver Mounted	0.77 (27.02)		760	1332	1068	73	<3	
7.5	HR07PR					200							1.04 (37.0)

Regeneration 50 Hz Enclosed - Fixed and Regulated Speed



Motor Power (kW)	Model	Voltage/Phase	Starter Type	Maximum FAD m ³ /min (cfm)		Dimensions (mm)			Noise dB(A)	Air Quality (mg/m ³)
				7 bar	10 bar	Depth	Width	Height		
4.0	HR04E	400V 3Ph	SD	0.68 (24.0)	0.57 (20.1)	680	630	1055	66	<3
5.5	HR05E			0.91 (32.1)	0.71 (25.1)					
7.5	HR07E			1.25 (44.1)	1.00 (35.0)					
7.5	HR07E RS	400V 3Ph	SD	-	0.97 (34.3)	680	630	1055	70	<3

Enclosed - Fixed Speed



Motor Power (kW)	Model	50Hz		60Hz		Maximum FAD m ³ /min (cfm)				Dimensions (mm)			Noise dB(A)	Air Quality (mg/m ³)
		Voltage/Phase	Starter Type	Voltage/Phase	Starter Type	50Hz		60Hz		Depth	Width	Height		
						8 bar	10 bar	8 bar	10 bar					
11.0	HV11	400V 3Ph	SD	460V 3Ph	DOL	1.63 (57.6)	1.41 (49.8)	1.48 (52.4)	1.29 (45.6)	850	700	1550	69	<3
15.0	HV15					2.21 (78.1)	2.01 (71.0)	1.90 (67.1)	1.65 (58.4)					
18.0	HV18					2.88 (101.7)	2.55 (90.1)	2.80 (99.0)	2.44 (86.2)					
22.0	HV22					3.60 (127.1)	2.96 (104.5)	3.25 (114.6)	2.83 (100.0)					
30.0	HV30					5.00 (176.6)	4.31 (152.2)	4.43 (156.5)	3.86 (136.2)					
37.0	HV37					5.95 (210.1)	5.07 (179.0)	5.48 (193.7)	4.77 (168.5)					
45.0	HV45			7.33 (258.9)	6.54 (231.0)	6.54 (231.0)	5.73 (202.3)	1130	900	1640	73			

Note: The 50 Hz / 400 Volts / 3 Phase Regulated Speed (RS) models also cover 60 Hz / 460 Volts / 3 Phase

Enclosed - Regulated Speed (RS)



Motor Power (kW)	Model	Voltage/Phase		Starter Type	Maximum FAD m ³ /min (cfm)			Dimensions (mm)			Noise dB(A)	Air Quality (mg/m ³)
		50Hz	60Hz		6 bar	8 bar	10 bar	Depth	Width	Height		
11.0	HV11RS	400V 3Ph	460V 3Ph	v	1.74 (61.6)	1.56 (55.0)	1.37 (48.5)	850	700	1550	69	<3
15.0	HV15RS				2.29(80.8)	2.03 (71.6)	1.72 (60.7)					
18.0	HV18RS				2.96 (104.6)	2.75 (96.9)	2.51 (88.5)					
22.0	HV22RS				3.53 (124.5)	3.22 (113.8)	3.07 (108.3)					
30.0	HV30RS				5.38 (189.9)	4.87 (171.9)	4.51 (159.3)					
37.0	HV37RS				6.17 (217.8)	5.72 (202.1)	5.27 (186.1)					
45.0	HV45RS				7.47 (263.7)	6.90 (243.5)	6.51 (230.0)					

Hypac 50 Hz Enclosed



Motor Power (kW)	Model	Configuration	Voltage/Phase	Starter Type	Receiver Capacity (litres)	Package Dimensions (mm)			Ambient Temp Min - Max (°C)	Pressure Dew Point (°C)	Air Quality (mg/m ³)	
						Depth	Width	Height				
4.0	HR04	HRER	400V 3Ph	SD	260	685	1146	1165	0-40	8	<3	
5.5	HR05											
7.5	HR07 / HR07RS	HRER / RS			272	1187	1355	1550				<2
11	HV11 / HV11RS											
15	HV15 / HV15RS											
18	HV18 / HV18RS											
22	HV22 / HV22RS											
4.0	HR04	HRED	400V 3Ph	SD	-	968	630	1078	0-40	3	<1	
5.5	HR05											
7.5	HR07 / HR07RS	HRED / RS			825	1215	1550	<1				
11	HV11 / HV11RS											
15	HV15 / HV15RS											
18	HV18 / HV18RS											
22	HV22 / HV22RS											

Air Solution 50 Hz Enclosed - The Complete Package



Motor Power (kW)	Model	Configuration	Voltage/Phase	Starter Type	Receiver Capacity (litres)	Package Dimensions (mm)			Ambient Temp Min - Max (°C)	Pressure Dew Point (°C)	Air Quality (mg/m ³)				
						Depth	Width	Height							
1.1	HV01RM	Receiver Mounted + Membrane Dryer	400V 3Ph	DOL	75	300	1120	730	0 - 40	30*	<1				
2.2	HV02RM														
4.0	HV04RM														
4.0	HR04	AERD	400V 3Ph	SD	-	260	968	1146	0 - 40	3	<1				
5.5	HR05														
7.5	HR07 / HR07RS					Integrated Refrigerant Dryer & Receiver	272	1187				1355	1550	3	<1
11	HV11 / HV11RS														
15	HV15 / HV15RS														
18	HV18 / HV18RS														
22	HV22 / HV22RS														

Note: The only 60 Hz model available is the HV01RM

Starter Types:

DOL Direct On Line

SD Star Delta

V Regulated Speed (RS)

Free Air Delivered (FAD) according to BS ISO1217:2009-Annex B, C and E

*Below ambient. Both fixed speed and regulated speed compressors operate up to 45°C ambient

Hydrovane compressors are designed for indoor installation under cover only.

©hydrovane

www.hydrovaneproducts.com

Global Expertise Local solutions



Supplied by your local Authorised Hydrovane Distributor:

Gardner Denver Ltd
Claybrook Drive, Redditch,
Worcestershire B98 0DS UK.

T. +44 (0)1527 525522 / 838200

F. +44 (0)1527 521140

E. hydrovane-info.uk@gardnerdenver.com



Certificate No. LRQ 0860349

© Gardner Denver Ltd Hydrovane is part of the Gardner Denver Group. Gardner Denver policy is one of continuous improvement and we therefore reserve the right to alter specifications without prior notice. All products are sold subject to the Company's conditions of sale.

Specifications subject to change without notice.
Copyright 2016 Gardner Denver.

Hydrovane is a brand of Gardner Denver

**Gardner
Denver**

Your Ultimate Source for Pressure and Vacuum

G599GB - 04/2016