

HPC | Compressed
Air Systems

Dry-running Rotary Screw Compressors

DSG-2 Series

Two-stage, free air delivery up to 30.1 m³/min, pressure 4, 6, 8 and 10 bar



OILFREE.AIR 

DSG-2 series

The new dimension in oil-free compression

Two-stage dry-running KAESER rotary screw compressors not only impress with their meticulous design, but also with their many innovative details - all of course with renowned KAESER quality.

Long-term efficiency

Compressed air simply has to be available where and whenever it is needed. KAESER dry-running two-stage rotary screw compressors are therefore built to last and to ensure many years of dependable service. Comprising tried and tested components that have been developed as a result of KAESER's near century of experience in mechanical engineering, KAESER compressors deliver the durability and compressed air availability to meet even the toughest of demands.

Innovation you can trust

Using all of the advantages that KAESER's advanced Research and Development Centre in Coburg has to offer, KAESER's engineers designed every detail of the two-stage dry-running rotary screw air end with maximum efficiency and performance in mind. As a result, KAESER dry-running rotary screw compressors, for example, are available with drive powers up to 355 kW (FSG-2 series).

Efficiency as standard

KAESER quality and expertise really count when it comes to those all-important total system costs for asset investments such as compressors, or complete compressed air supply systems. Lowest possible compressed air costs and maximum availability can be guaranteed only through a combination of perfect interplay between energy efficiency and service / maintenance, and by viewing the compressed air supply system as a whole.

Service-friendly

These versatile systems were engineered for maximum ease-of-use and servicing right from the outset of the design stage. Fewer wearing parts and the use of premium quality materials ensure reduced maintenance requirement, longer service intervals and extended service life. Excellent component accessibility as a result of generously sized maintenance doors and a swing-out cooler are just some of the features that make servicing so effortless.

Potential energy cost savings through heat recovery

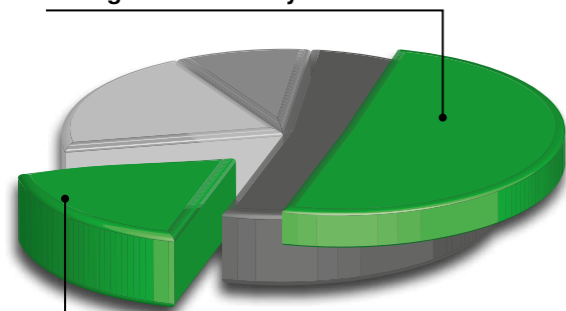

Energy cost savings through system optimisation



- Compressed air system investment
- Maintenance costs
- Energy costs
- Potential energy cost savings

Innovation – Quality – KAESER

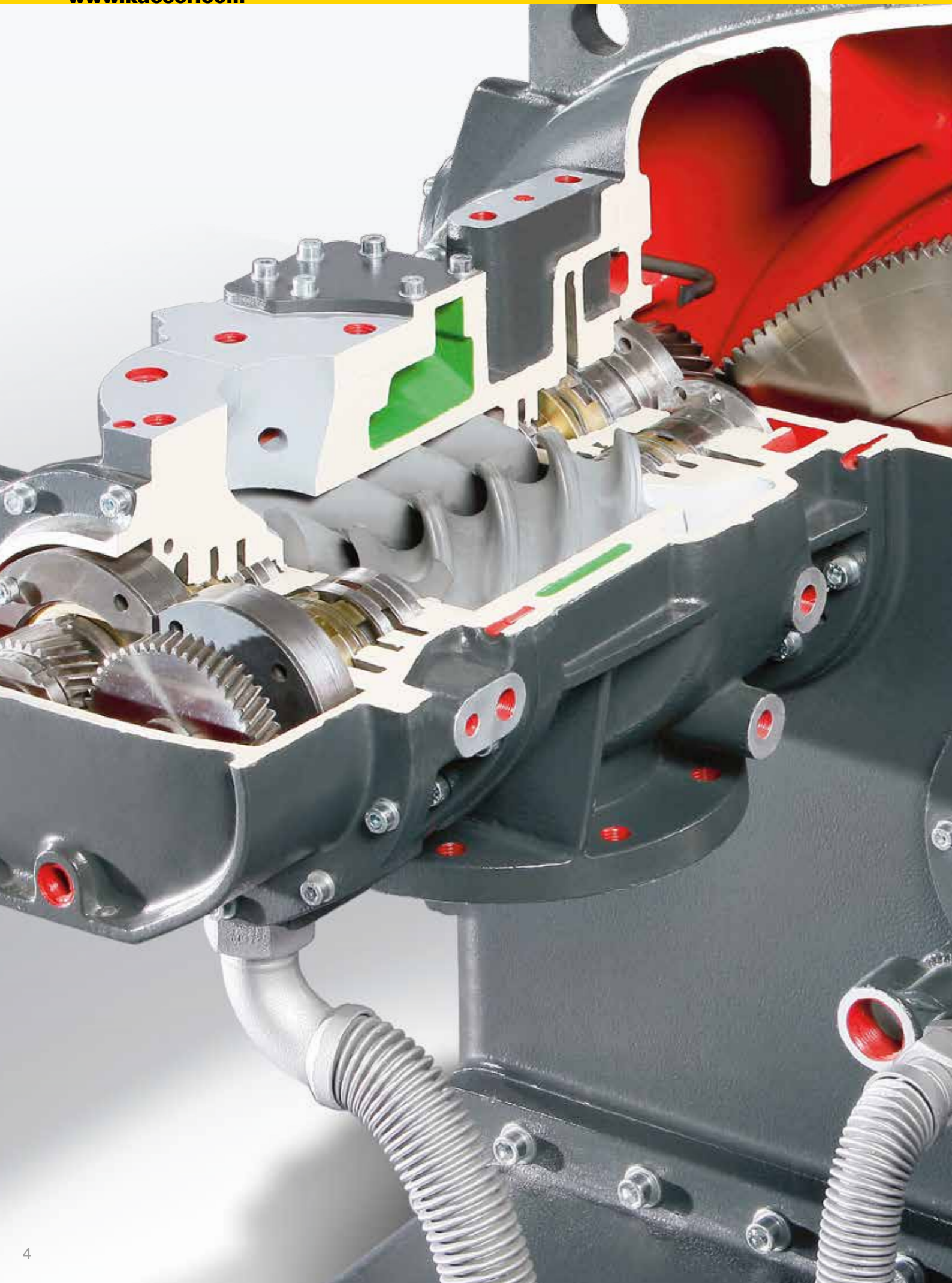

Image: DSG 180-2 RD SFC



i.HOC

(Integrated Heat of Compression Dryer)



DSG-2 series

Convincing technology



Proven airends

At the heart of every KAESER dry-running rotary screw compressor lies a tried and tested dry-running, two-stage rotary screw airend. Providing optimum performance and dependability, every airend ensures maximum efficiency throughout its entire service life.



Durable coating

The blasted and bonderised rotors are treated using the special "Ultra Coat" process to produce an innovative and durable coating which is resistant to temperatures of up to 300 °C. Since this cost-reducing coating is highly abrasion-resistant, its sealing and protection performance remains consistent even after years of operation.



Chromium steel rotors

The second compression stage's rotors are made from stainless steel, which eliminates the risk of rotor seizing or jamming caused by corrosion.



Airend cooling

In the places where things really heat up, i.e. in the second compression stage, coolant flows directly through the walls of the airend housing to ensure best possible heat dissipation and therefore efficiency.

DSG-2 series

Efficient drive systems with advanced control



SIGMA CONTROL 2

The SIGMA CONTROL 2 ensures efficient control and system monitoring. The large display and RFID reader provide easy communication and maximum security, whilst the SD-card slot greatly simplifies fault analysis tasks.



High efficiency IE3 drive motors

DSG-2 series compressors are equipped exclusively with premium efficiency IE3 AC motors. For SFC models, KAESER uses optimised frequency converter motors with insulated motor bearings.



Optimised drive systems

Perfect harmonisation of the frequency converter and drive motor ensures exceptional efficiency across the machine's entire operating range and minimises machine vibrations. Moreover, the thermally optimised control cabinet allows unhindered operation in ambient temperatures of up to + 45°C.



Easy-access coupling

The electric motor directly drives the airend with near zero transmission loss via a maintenance-free coupling. As there is no need for complicated disassembly work, the easy-access coupling can be exchanged quickly and easily.



DSG-2 series

Quality in detail



Hydraulic inlet valve

The hydraulically operated inlet valves on KAESER dry-running rotary screw compressors are unaffected by contamination and condensate. This makes them more reliable and easier to maintain than pneumatic valves.



Fibre-free pulse dampers

KAESER's new fibre-free pulse dampers keep pressure losses to an absolute minimum, help maintain consistent air quality and, unlike fibre versions, do not present a source of contamination for the compressed air.



Dependable oil reservoir ventilation

The microfilter in the oil tank ventilation system prevents intake of oil-laden air. This is a key detail to ensure that compressed air quality is reliably maintained at all times.



Highly efficient condensate separator

Thanks to its flow-optimised design, the newly developed condensate separator reliably separates the condensate downstream from the air coolers, with minimal pressure loss.



DSG-2 series

Efficient cooling systems

Air cooling:



Air cooling reduces operating costs

Air-cooled versions are designed to meet the demands of even the toughest operating environments and can be used in ambient temperatures as high as +45°C. The low and high pressure stages are each equipped with their own stainless steel / aluminium cooler combinations.



KAESER standstill fan

Due to the standstill fan, the large radial fan of air-cooled systems can be shut down when the compressor is in standby mode. Heat trapped in the compressor is then safely removed through the energy-saving, temperature-controlled standstill fan.

Water cooling:



Parallel heat exchanger

Both the low and high pressure stages of water-cooled KAESER dry-running rotary screw compressors are equipped with their own dedicated parallel heat exchanger for enhanced heat transfer. This optimised cooling results in improved specific power performance.



Optimised water cooling

Water-cooled models are equipped with high efficiency air / water heat exchangers. CuNi10Fe cooling pipes with internal lamella fins provide optimum heat transfer and lowest possible compressed air discharge temperatures with minimal pressure loss.

- 1 Radial fan for optional heat exchanger downstream from the i.HOC rotation dryer
- 2 Cooler combination, air-cooled DSG-2
- 3 Radial fan cooler combination

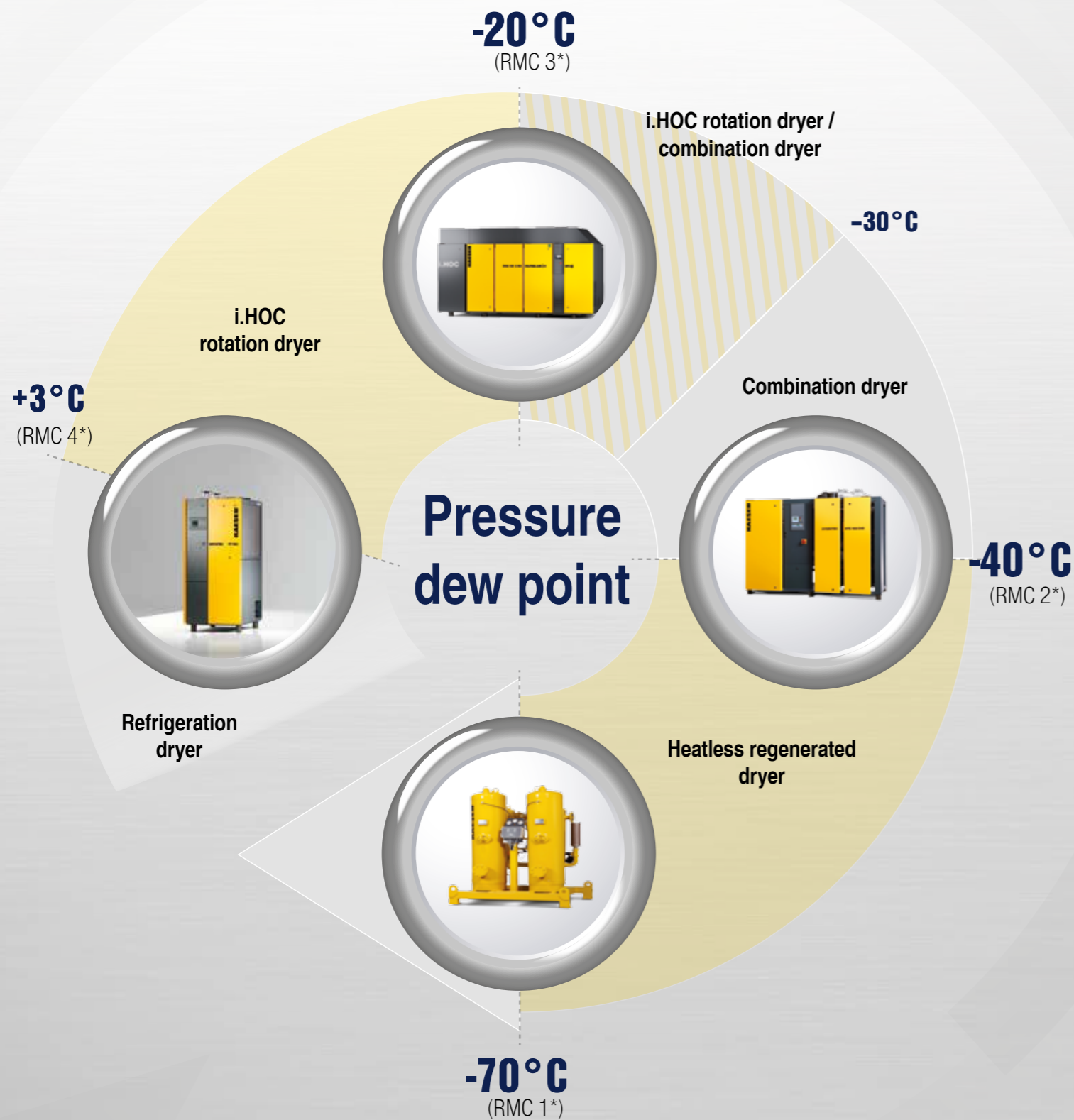

*) RMC = Residual Moisture Class as per ISO 8573-1(2010)

Clean technology

Compressed air drying for dry-running compressors



Refrigeration dryer

Even for dry-running rotary screw compressors, refrigeration dryers are the go-to choice for delivering best possible energy efficiency and favourable investment cost when requiring pressure dew points to + 3°C. Pressure dew points below + 3°C are the domain of desiccant dryers.



Combination dryer

HYBRITEC dryers combine the energy-saving operation of modern refrigeration dryers with the ultra-low pressure dew points of desiccant dryers. HYBRITEC dryers achieve pressure dew points as low as - 40°C with exceptional efficiency.



i.HOC rotation dryer

The optional i.HOC rotation dryer for integration in the rotary screw compressor reliably and efficiently achieves pressure dew points as low as - 30°C. The hot compressed air from the second compression stage is used to regenerate the desiccant.



Heatless regenerated dryer

KAESER's DC series heatless regenerated desiccant dryers achieve pressure dew points to - 70°C, even under extreme operating conditions.



Image: Example of a KAESER station that has been expanded with the installation of a water-cooled DSG 290-2 RD SFC dry-running rotary screw compressor.



- 1** Regeneration air inlet
- 2** Regeneration air outlet
- 3** Condensate separation
- 4** Radial fan inlet
- 5** i.HOC rotation dryer outlet

i.HOC

Dependable pressure dew point through innovative process engineering

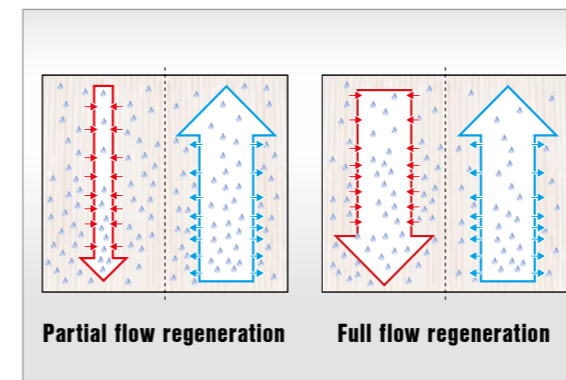

Full flow regeneration

i.HOC utilises 100 % of the available hot compressed air from the 2nd stage for regeneration. This consequently increases the potential for moisture discharge compared with dryers that use only partial flow. This applies especially with compressor partial load and high coolant temperatures.



Perfect performance

The i.HOC rotation dryer's intelligent control ensures dew point stability even with fluctuating air deliveries and at compressor partial load. When commissioned, the target pressure dew point is reached after just one rotation of the drum.

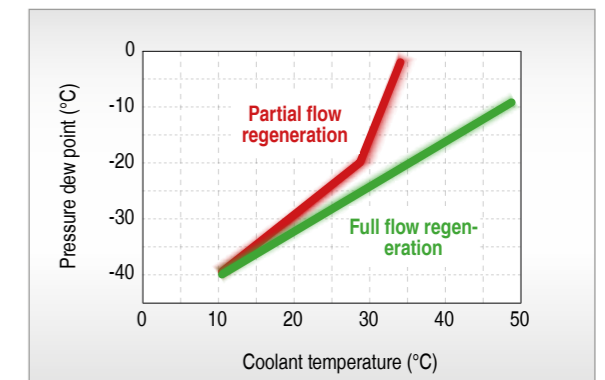

Drying even near the limit

The advantages of full flow regeneration become obvious, especially with increased coolant temperatures. KAESER rotation dryers achieve outstanding drying results even without additional electric heating of the regeneration air.

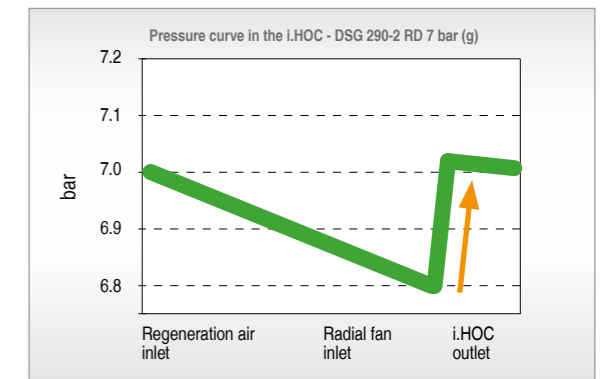

Pressure loss? On the contrary!

The radial fan in the bottom of the rotation dryer equalizes drying process pressure losses as required, thereby guaranteeing maximum pressure dew point stability and quality – the pressure at the i.HOC dryer outlet is higher even than at the inlet!

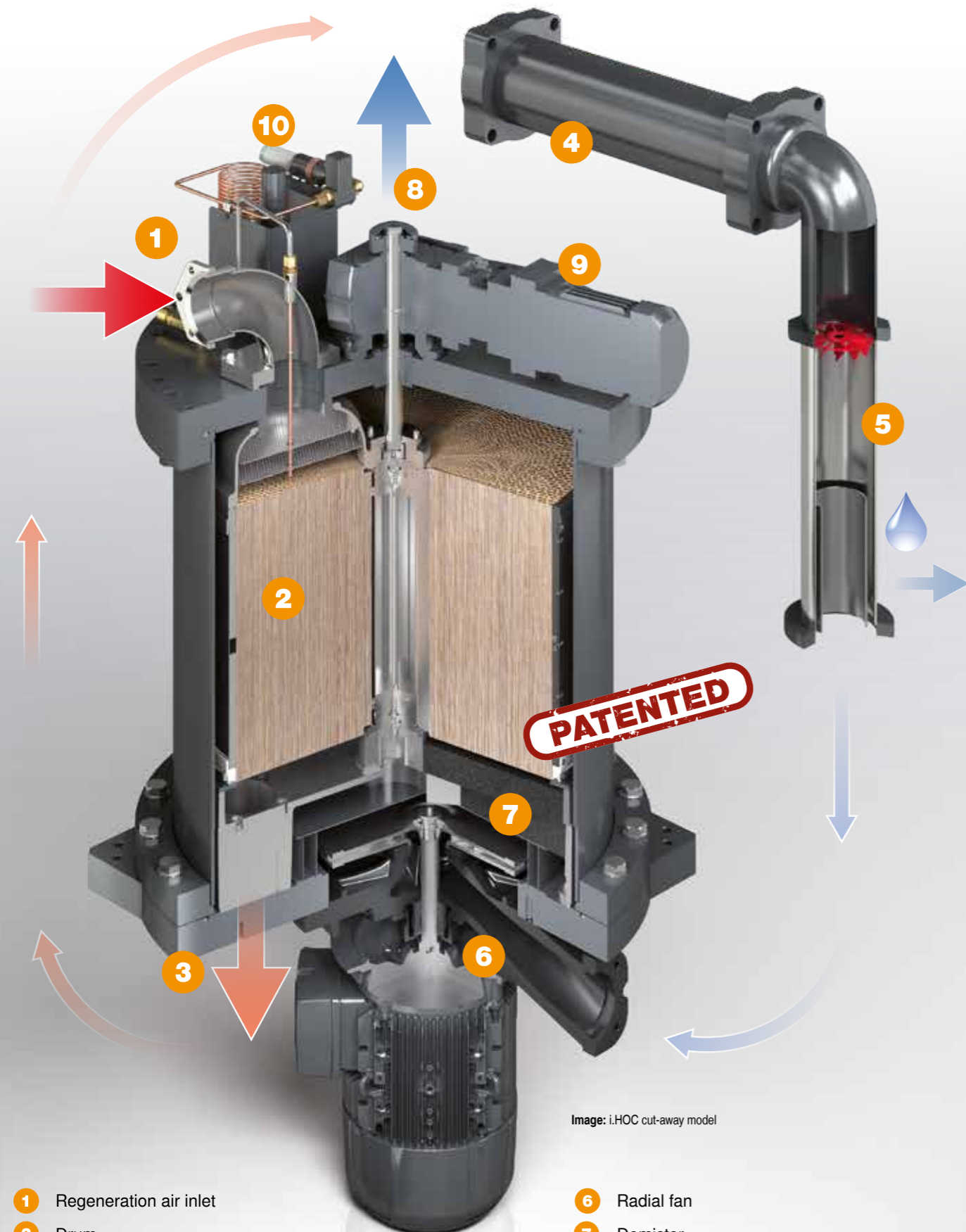

Image: i.HOC cut-away model

- | | | | |
|---|-------------------------|----|--------------------------------------|
| 1 | Regeneration air inlet | 6 | Radial fan |
| 2 | Drum | 7 | Demister |
| 3 | Regeneration air outlet | 8 | i.HOC rotation dryer outlet |
| 4 | Heat exchanger stage 2 | 9 | Drum motor |
| 5 | Condensate separator | 10 | Pressure dew point sensor (optional) |

i.HOC

(Integrated Heat of Compression Dryer)

Precision for efficiency and low pressure dew points



Precision drum

The silica gel desiccant is bedded in a precision manufactured drum with exceptionally high run-out qualities. Incorrect flows within the dryer and resulting pressure dew point fluctuations are therefore reliably prevented.



Variable speed drum motor

The speed of the drum is automatically adjusted according to actual compressor performance in order to regenerate the desiccant as effectively as possible. This is the key to ensuring consistently low pressure dew points.



Durable & efficient

The flow-optimised radial fan installed in the base of the dryer is significantly more efficient than the stipulations set forth by EC directive 327/2011. Maximum availability is ensured by the wear-resistant, gas-lubricated sliding ring seal.



External condensate separation

i.HOC uses a highly efficient condensate separator downstream from the heat exchanger in the second compression stage in order to separate the condensate that precipitates during the regeneration process **outside of the dryer**. This protects the drum against potential damage from water droplets.

Heat recovery potential: Water-cooled DSG 2

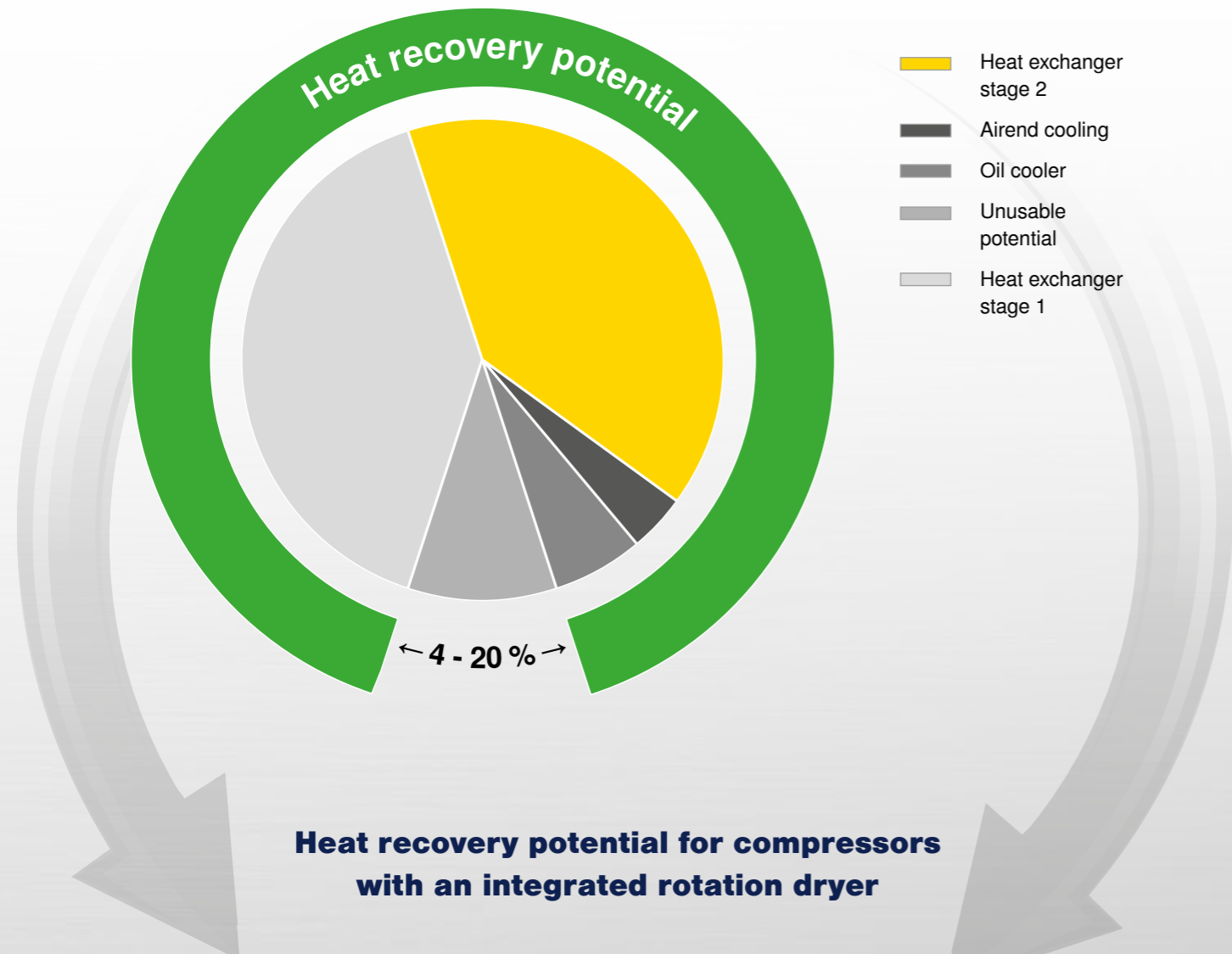

- Heat exchanger stage 2
- Airend cooling
- Oil cooler
- Unusable potential
- Heat exchanger stage 1

Heat recovery potential for compressors with an integrated rotation dryer

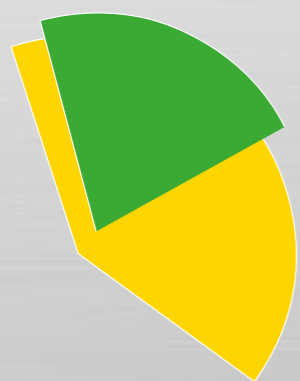

Partial flow regeneration

The heat recovery potential of the 2nd stage heat exchanger is inherently lower for dryers with partial flow regeneration than it is for those with full flow regeneration.

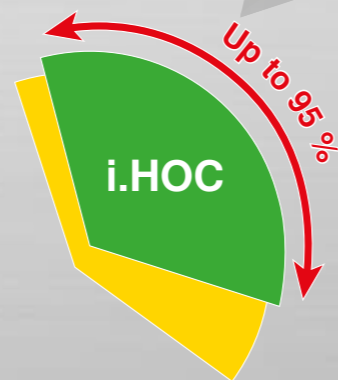

KAESER full flow regeneration

With a water-cooled DSG-2 equipped with an integrated i.HOC rotation dryer, up to 95% of the heat recovery potential of the 2nd stage heat exchanger is retained.

Heat recovery

Efficient use of hot compressed air and compressor exhaust air



Direct compressed air use

Using KAESER hot air control, hot compressed air can be seamlessly incorporated into your production processes. The SIGMA CONTROL 2 can even be used to increase the temperature of the hot air as required.



Desiccant compressed air drying

Both air-cooled and water-cooled DSG-2 systems enable the energy-efficient use of hot compressed air to regenerate the desiccant in the KAESER i.HOC rotation dryer.



Space heating with warm exhaust air

Heating made easy: Thanks to radial fans with high residual thrust, the reusable (warm) air from air-cooled DSG-2 systems can be easily ducted away to spaces that require heating – and usually without the need for additional fans.

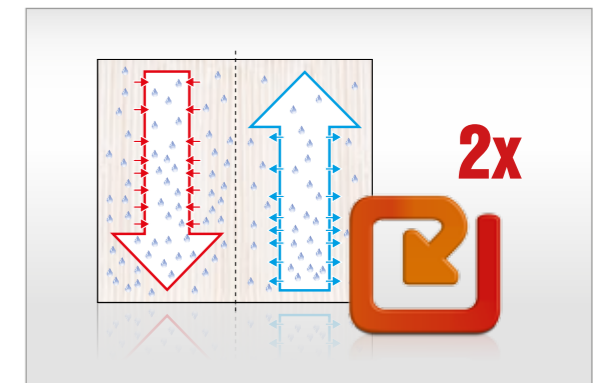

Hot compressed air used twice

In water-cooled DSG-2 systems with i.HOC, it is possible to not only use the hot compressed air for regeneration of the desiccant, but also to subsequently use it for heat recovery purposes via the second stage heat exchanger.

KAESER heat recovery

**Amortisation
period
approximately
1 year**



Example amortisation calculation

Inlet temperature	20 °C
Relative humidity	30 %
Cooling water inlet (primary)	20 °C
Cooling water outlet (primary)	80 °C
Compressor power consumption DSG-180-2 8 bar(g)	142.5 kW
Heat recovery potential based on total power consumption	87 %
Recoverable heat capacity	124 kW
Annual operating hours	2500 hrs
Kilowatt hours per year	309,938 kWh
Energy costs	0.04 €/kWh
Energy cost savings per year	€12,398

Amortisation period Approximately 1 year

Heat recovery

Maximum savings with energy recovery

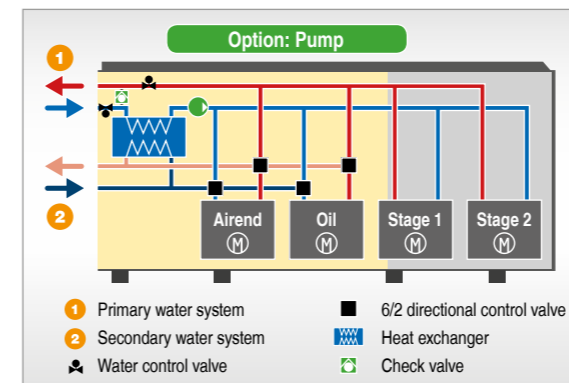

Reliable heat recovery

The separation of a primary and a secondary water system ensures reliable and safe air supply with optimum heat recovery.



Maximum availability

An optionally available complete internal water circuit (with pump, expansion tank, pressure-relief valve etc.) ensures reliable compressor operation during maintenance work on the primary water system outside of the compressor.

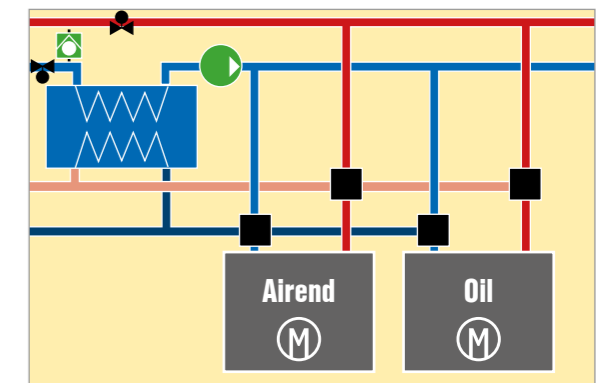

Flexible heat use

The ability to combine oil and jacket cooling provides maximum heat recovery potential. Moreover, uncoupling of the oil and jacket cooling when heat demand reduces also lowers compressor specific power requirement.



Electronically controlled cooling

To ensure maximum operational safety, the SIGMA CONTROL 2 compressor controller regulates the water volume flows in the primary and the secondary water systems via dedicated tight-sealing control valves.

Heat recovery flow diagram DSG-2

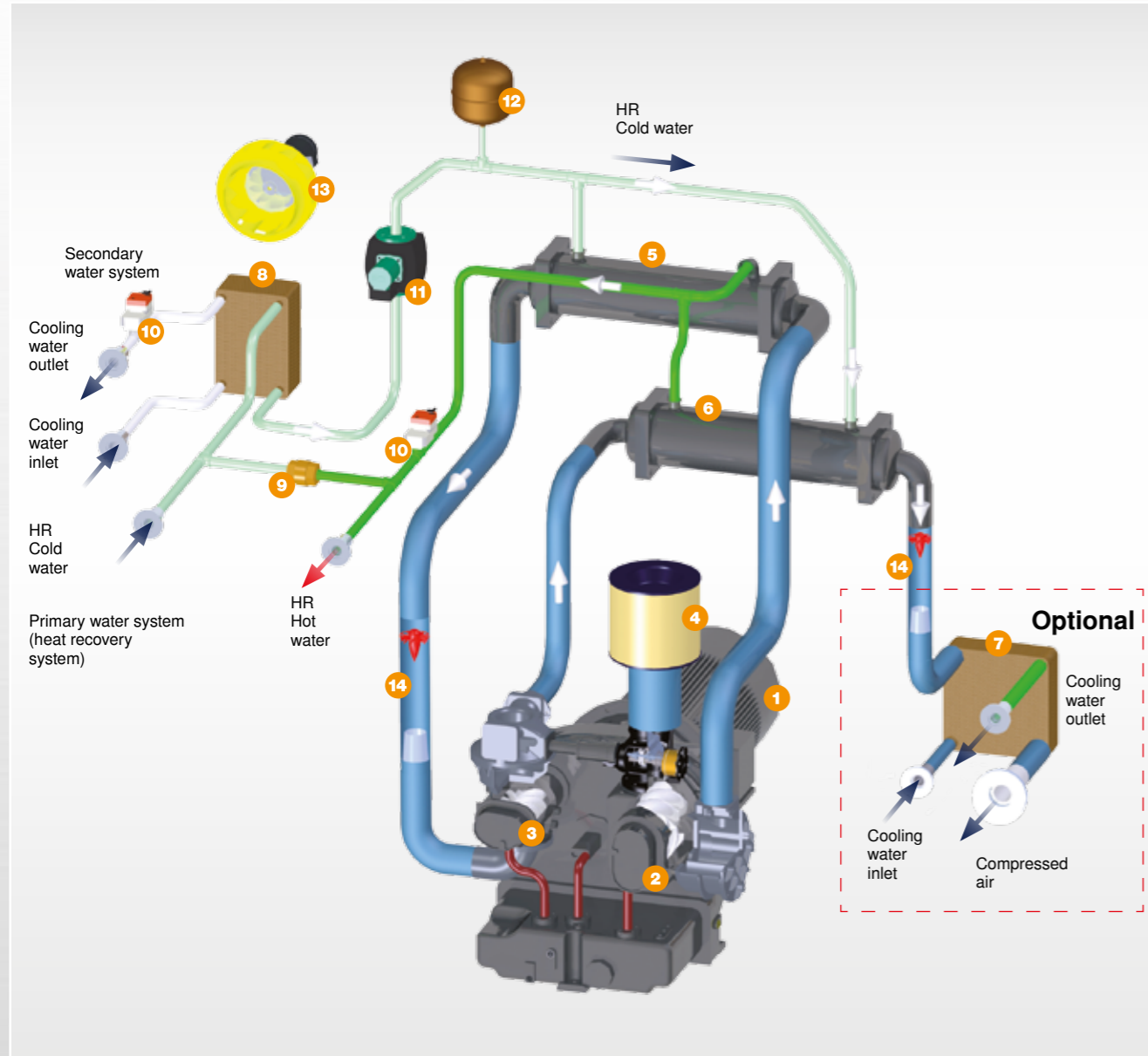

- | | |
|--|--|
| 1 Drive motor | 8 Heat exchanger (water/water) |
| 2 Low pressure stage (Stage 1) | 9 Check valve |
| 3 High pressure stage (Stage 2) | 10 Water control valve (actuated by SIGMA CONTROL 2) |
| 4 Inlet filter | 11 Pump |
| 5 Aircooler downstream from Stage 1 (air/water) | 12 Expansion tank |
| 6 Aircooler downstream from Stage 2 (air/water) | 13 Interior cooling fan |
| 7 Optional additional heat exchanger (air/water)
(Version as plate-type heat exchanger) | 14 Condensate separator |

Optional version with heat recovery (water-cooled systems only)

Heat recovery flow diagram DSG-2 RD

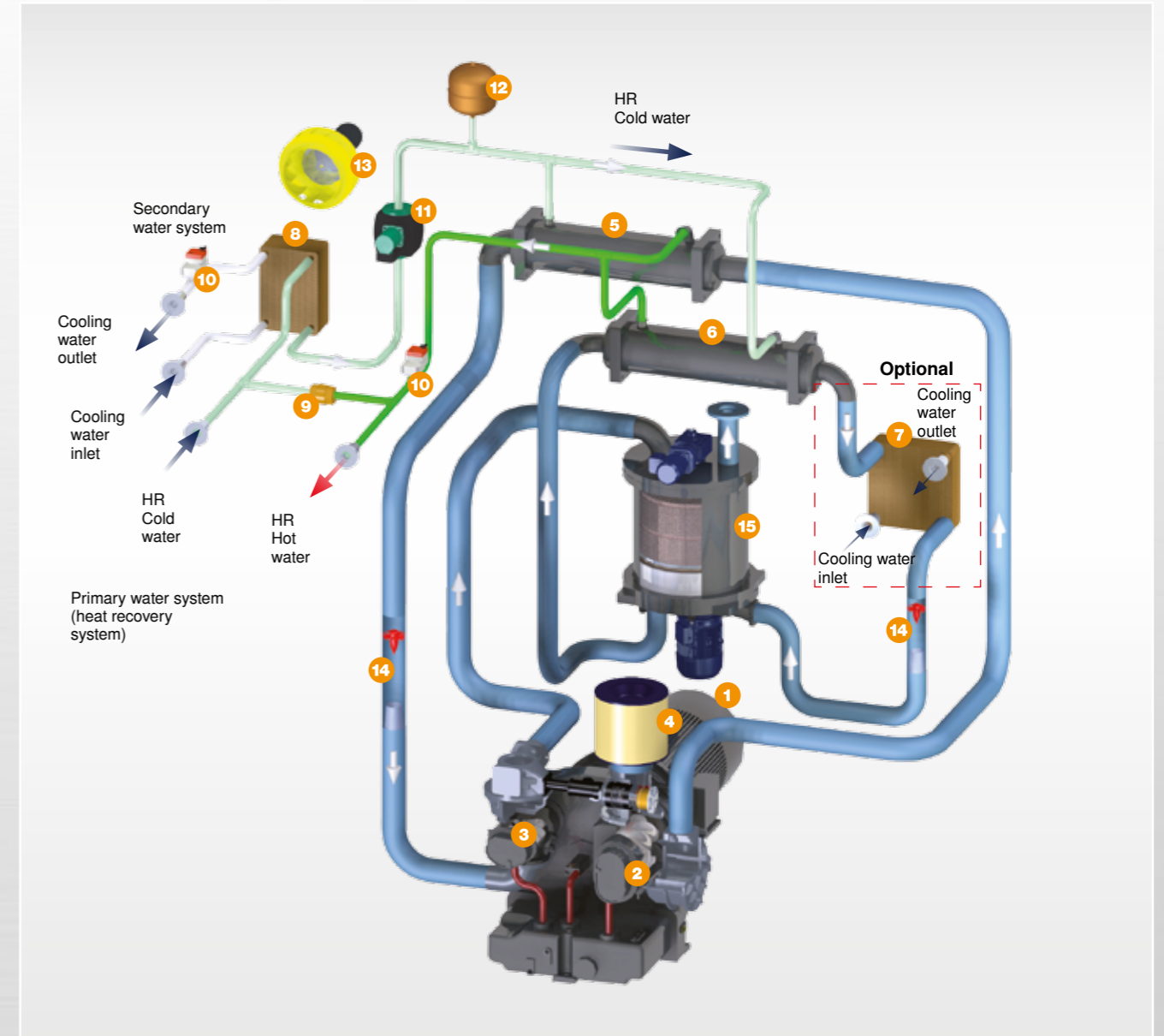

- | | |
|--|--|
| 1 Drive motor | 8 Heat exchanger (water/water) |
| 2 Low pressure stage (Stage 1) | 9 Check valve |
| 3 High pressure stage (Stage 2) | 10 Water control valve (actuated by SIGMA CONTROL 2) |
| 4 Inlet filter | 11 Pump |
| 5 Aircooler downstream from Stage 1 (air/water) | 12 Expansion tank |
| 6 Aircooler downstream from Stage 2 (air/water) | 13 Interior cooling fan |
| 7 Optional additional heat exchanger (air/water)
(Version as plate-type heat exchanger) | 14 Condensate separator |
| | 15 i.HOC rotation dryer |

Optional version with heat recovery (water-cooled systems only)

Layout >> DSG-2

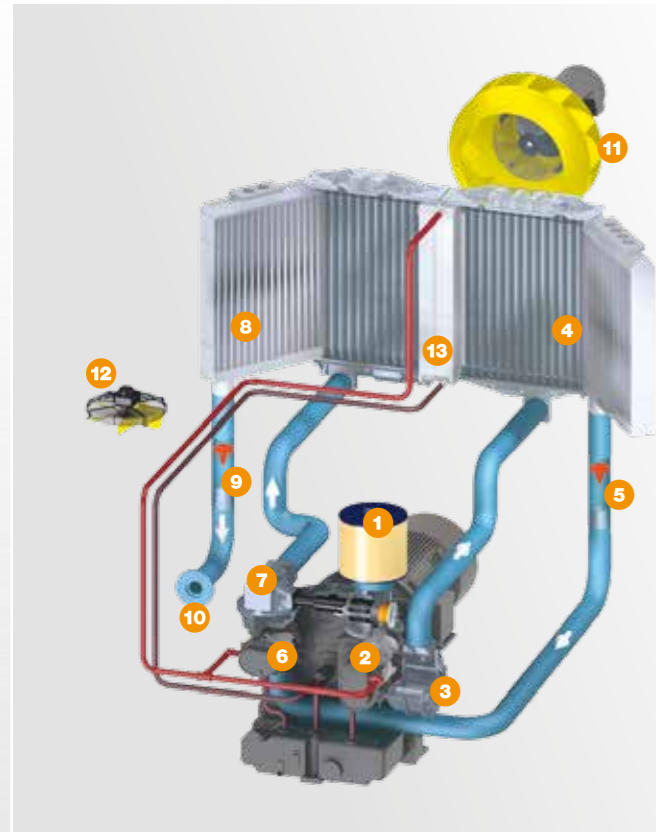

Air cooling

- 1 Air filter / air inlet
- 2 Low pressure stage (Stage 1, LP)
- 3 Pulse damper (Stage 1)
- 4 Air cooler Stage 1 (with pre-cooler)
- 5 Condensate separator
- 6 High pressure stage (Stage 2, HP)
- 7 Pulse damper (Stage 2)
- 8 Air cooler Stage 2 (with pre-cooler)
- 9 Condensate separator
- 10 Compressed air outlet
- 11 Radial fan
- 12 Temperature controlled standstill fan (for package at standstill)
- 13 Gear oil cooler

Image: Standard version DSG-2, air-cooled

Layout >> DSG-2 RD

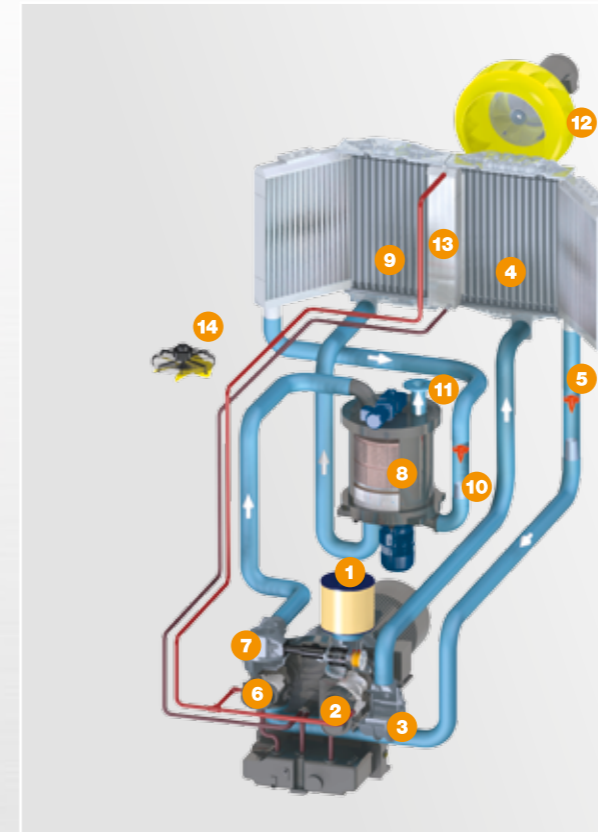

Air cooling

- 1 Air filter / air inlet
- 2 Low pressure stage (Stage 1, LP)
- 3 Pulse damper (Stage 1)
- 4 Air cooler Stage 1 (with pre-cooler)
- 5 Condensate separator
- 6 High pressure stage (Stage 2, HP)
- 7 Pulse damper (Stage 2)
- 8 i.HOC rotation dryer
- 9 Air cooler Stage 2 (with pre-cooler)
- 10 Condensate separator
- 11 Compressed air outlet
- 12 Radial fan
- 13 Gear oil cooler
- 14 Temperature controlled standstill fan (for package at standstill)

Image: Standard version DSG-2 RD, air-cooled

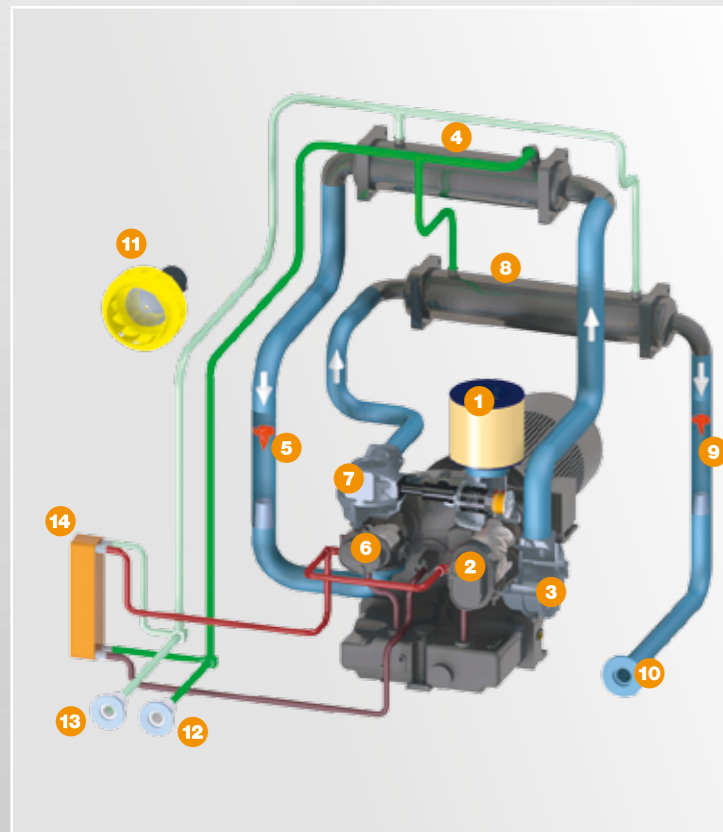

Water cooling

- 1 Air filter / air inlet
- 2 Low pressure stage (Stage 1, LP)
- 3 Pulse damper (Stage 1)
- 4 Air cooler Stage 1
- 5 Condensate separator
- 6 High pressure stage (Stage 2, HP)
- 7 Pulse damper (Stage 2)
- 8 Air cooler Stage 2
- 9 Condensate separator
- 10 Compressed air outlet
- 11 Interior cooling fan
- 12 Cooling water outlet
- 13 Cooling water inlet
- 14 Gear oil cooler

Image: Standard version DSG-2, water-cooled

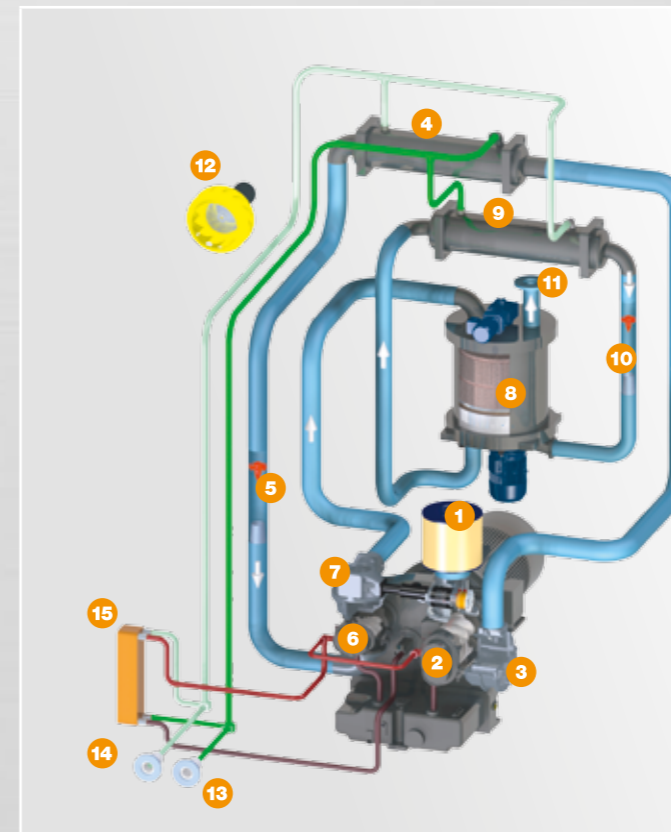

Water cooling

- 1 Air filter / air inlet
- 2 Low pressure stage (Stage 1, LP)
- 3 Pulse damper (Stage 1)
- 4 Air cooler Stage 1
- 5 Condensate separator
- 6 High pressure stage (Stage 2, HP)
- 7 Pulse damper (Stage 2)
- 8 i.HOC rotation dryer
- 9 Air cooler Stage 2
- 10 Condensate separator
- 11 Compressed air outlet
- 12 Interior cooling fan
- 13 Cooling water outlet
- 14 Cooling water inlet
- 15 Gear oil cooler

Image: Standard version DSG-2 RD, water-cooled

Equipment >> DSG-2

Complete unit

Dry-running rotary screw compressor with 2-stage compression; condensate separator, condensate drain and fibre-free pulse dampers for both compression stages; oil tank ventilation with microfilter, ready for operation, fully automatic, silenced.

Airend

2-stage, dry-running rotary screw airend with integrated gearing and collection tank for gear oil. Rotors feature durable coating. 2nd compression stage uses stainless steel rotors and jacket cooling.

Drive: Precision gearing as per Agma Q13/ DIN Class 5 with helical spur gears.

Drive motor

Premium efficiency IE3 drive motor, quality manufacture; IP 55 enclosure protection, Pt100 temperature sensor in windings; continuous measurement and monitoring of motor windings temperature.

Cooling

Optionally available with air- or water-cooling. Radial fan with separate drive motor. Exhaust air discharged upwards.

Air-cooled version:

Up to 200 kW with five coolers (2 cooler packages comprising a stainless steel and an aluminium cooler for compressed air, one cooler for gear oil).

Water-cooled version:

Up to 200 kW, two shell and tube heat exchangers comprising coated steel jacket and CuNi10Fe piping, one gear oil cooler.

Electrical components

Ventilated IP 54 control cabinet, automatic star-delta starter, overload relay, control transformer.

SIGMA CONTROL 2

Full-text display, 30 languages; soft touch pictogram keys; 'traffic light' style LEDs to indicate operating status; fully automatic monitoring and control; Dual, Quadro, and Dynamic control modes provided as standard; SD-card slot for data logging and updates; RFID reader; web server; interfaces: Ethernet; optional communications modules for: Profibus DP, Modbus, Profinet and Devicenet.

Options:

Hot air connection

DN 80 pipe connection at the pulse damper of the 2nd compression stage; direct use of hot compressed air, e.g. for DHC dryer or as hot process air.

KAESER hot air control

High temperature valve of quality manufacture; SIGMA CONTROL 2 regulates air temperature control downstream from the 2nd stage pulse damper.

Bolt-down machine mounts

Machine mounts for bolting to floor.

Silencer for air inlet opening

Air-cooled version:

Sound insulated connecting links before heat exchangers.

Cooling air filter mats

Air-cooled version:

Cooling air filter mats in the compressor intake area; reduces the contamination of the heat exchanger surfaces and inlet air filters.

Heat recovery

Water-cooled version:

heat recovery system can be optionally integrated; parallel switched tube-type heat exchanger; safety cooling system; safety pump; expansion tank; water control valves.

Additional heat exchanger downstream from 2nd stage.

Water-cooled version:

Version as plate-type heat exchanger; reduces outlet temperature for compressors with heat recovery



Image: Pulsation dampener

Equipment >> DSG-2 RD

Complete unit

Dry-running rotary screw compressor with 2-stage compression; condensate separator, with integrated i.HOC rotation dryer; condensate drain and pulse dampers for both compression stages; oil tank ventilation with microfilter, ready for operation, fully automatic, silenced.

Compressor airend, drive motor, cooling, electrical components and SIGMA CONTROL 2 described as per equipment for DSG-2.

i.HOC

Integrated i.HOC rotation dryer; silica gel desiccant fully contained in precision-machined drum with axial flow; axial cylinder motor; helical gear motor; IP 55 enclosure protection; integrated radial fan; special FC drive motor, IP 55 enclosure protection; low-wear gas-lubricated sliding ring seal for seal the motor shaft of the radial fan.

Options:

Heat exchanger downstream from rotation dryer

Air-cooled version:

Version as aluminium block heat exchanger with radial fan; reduces the compressed air discharge temperature from the compressor.

Water-cooled version:

Version as plate-type heat exchanger; reduces the compressed air discharge temperature from the compressor.

Pressure dew point sensor

Pressure dew point sensor of quality manufacture; evaluation via SIGMA CONTROL 2; IP65.



Image: DSG-2 RD A with heat exchanger downstream from the rotation dryer

Bolt-down machine mounts

Machine mounts for bolting to floor.

Silencer for air inlet opening

Air-cooled version:

Sound insulated connecting links before heat exchangers.

Cooling air filter mats

Air-cooled version:

Cooling air filter mats in the compressor intake area; reduces the contamination of the heat exchanger surfaces and inlet air filters.

Heat recovery

Water-cooled version:

Parallel switched tube-type heat exchanger; heat exchanger (water / water); pump; expansion tank; water control valves.

Additional heat exchanger downstream from 2nd stage

Water-cooled version:

Version as plate-type heat exchanger; reduces compressed air inlet temperature in the drying section of the rotation dryer and consequently reduces the pressure dew point compared to the standard package.

Technical specifications >> DSG-2

Air- / water-cooled

Model	Rated motor power	Gauge pressure	Air-cooled version				Water-cooled version			
			FAD Complete package at working pressure ¹⁾	Dimensions W x D x H	Sound pressure level (with ducting) ²⁾	Weight	FAD Complete package at max. overpressure ¹⁾	Dimensions W x D x H	Sound pressure level (with ducting) ²⁾	Weight
			m ³ /min	mm	dB(A)	kg	m ³ /min	mm	dB(A)	kg
DSG 140-2	90	4	18.5	3435 x 1750 x 2385	76	3400	18.5	3435 x 1750 x 2060	69	3100
		6	16.2				16.2			
		8	13.2				13.2			
		10	13.1				13.1			
DSG 180-2	110	4	21.7	3435 x 1750 x 2385	77	3550	21.7	3435 x 1750 x 2060	70	3250
		6	19.2				19.2			
		8	18.4				18.4			
		10	16.1				16.1			
DSG 220-2	132	4	26.2	3435 x 1750 x 2385	77	3700	26.2	3435 x 1750 x 2060	71	3400
		6	23.0				23.0			
		8	21.6				21.6			
		10	19.1				19.1			
DSG 260-2	160	4	28.6	3435 x 1750 x 2385	78	3850	28.6	3435 x 1750 x 2060	74	3550
		6	26.1				26.1			
		8	26.0				26.0			
		10	22.9				22.9			
DSG 290-2	200	6	28.6	3435 x 1750 x 2385	80	4000	28.6	3435 x 1750 x 2060	75	3700
		8	28.5				28.5			
		10	26.0				26.0			

SFC versions with variable speed drive

Model	Rated motor power	Gauge pressure	Air-cooled version				Water-cooled version			
			FAD Complete package at working pressure ¹⁾	Dimensions W x D x H	Sound pressure level (with ducting) ²⁾	Weight	FAD Complete package at max. overpressure ¹⁾	Dimensions W x D x H	Sound pressure level (with ducting) ²⁾	Weight
			m ³ /min	mm	dB(A)	kg	m ³ /min	mm	dB(A)	kg
DSG 180-2 SFC	110	4	8.6 - 22.5	3435 x 1750 x 2385	78	4150	8.6 - 22.5	3435 x 1750 x 2060	71	3850
		6	9.5 - 20.8				9.5 - 20.8			
		8	8.5 - 18.6				8.5 - 18.6			
		10	9.5 - 16.4				9.5 - 16.4			
DSG 220-2 SFC	132	4	7.8 - 22.5	3435 x 1750 x 2385	78	4300	7.8 - 22.5	3435 x 1750 x 2060	72	4000
		6	8.7 - 22.5				8.7 - 22.5			
		8	9.5 - 21.8				9.5 - 21.8			
		10	10.0 - 19.5				10.0 - 19.5			
DSG 260-2 SFC	160	4	8.6 - 27.7	3435 x 1750 x 2385	79	4450	8.6 - 27.7	3435 x 1750 x 2060	75	4150
		6	9.4 - 27.7				9.4 - 27.7			
		8	9.6 - 25.4				9.6 - 25.4			
		10	10.3 - 23.3				10.3 - 23.3			
DSG 290-2 SFC	200	4	9.1 - 30.1	3435 x 1750 x 2385	81	4600	9.1 - 30.1	3435 x 1750 x 2060	76	4300
		6	10.3 - 30.0				10.3 - 30.0			
		8	11.5 - 30.0				11.5 - 30.0			
		10	12.7 - 28.2				12.7 - 28.2			

Dimensions

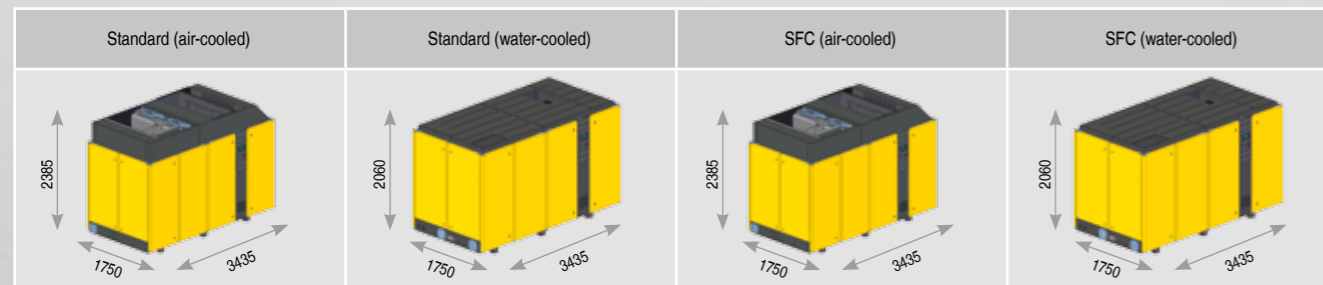

¹⁾ Free air delivery of complete package as per ISO 1217:2009, Annex C: Absolute inlet pressure 1 bar (a), cooling and air inlet temperature 20 °C
²⁾ Sound pressure level as per ISO 2151 and basic standard ISO 9614-2, tolerance: ± 3 dB (A)

11-bar versions available upon request.
 Specifications subject to change without notice

Technical specifications >> DSG-2 RD

Air- / water-cooled versions with rotation dryer

Model	Rated motor power	Gauge pressure	Air-cooled version					Water-cooled version				
			FAD Complete package at working pressure ¹⁾	Dimensions W x D x H	Pressure dew point	Sound pressure level (with ducting) ²⁾	Weight	FAD Complete package at max. overpressure ¹⁾	Dimensions W x D x H	Pressure dew point ³⁾	Sound pressure level (with ducting) ²⁾	Weight
			m ³ /min	mm	°C	dB(A)	kg	m ³ /min	mm	°C	dB(A)	kg
DSG 140-2 RD	90	6	16.2	4270 x 1750 x 2385	-26	76	4500	16.2	4270 x 1750 x 2060	-23	69	4200
		8	13.2		-34			13.2		-32		
		10	13.1		-36			13.1		-36		
		10	13.1		-36			13.1		-36		
DSG 180-2 RD	110	6	19.2	4270 x 1750 x 2385	-26	77	4650	19.2	4270 x 1750 x 2060	-24	70	4350
		8	18.4		-33			18.4		-33		
		10	16.1		-36			16.1		-36		
		10	16.1		-36			16.1		-36		
DSG 220-2 RD	132	6	23.0	4270 x 1750 x 2385	-25	77	4800	23.0	4270 x 1750 x 2060	-24	71	4500
		8	21.6		-32			21.6		-33		
		10	19.1		-35			19.1		-36		
		10	19.1		-35			19.1		-36		
DSG 260-2 RD	160	6	26.1	4270 x 1750 x 2385	-24	78	4950	26.1	4270 x 1750 x 2060	-24	74	4650
		8	26.0		-31			26.0		-32		
		10	22.9		-34			22.9		-36		
		10	22.9		-34			22.9		-36		
DSG 290-2 RD	200	6	28.6	4270 x 1750 x 2385	-23	80	5100	28.6	4270 x 1750 x 2060	-23	75	4800
		8	28.5		-30			28.5		-32		
		10	26.0		-33			26.0		-36		
		10	26.0		-33			26.0		-36		

SFC versions with rotation dryer and variable speed drive

Model	Rated motor power	Gauge pressure	Air-cooled version					Water-cooled version				
			FAD Complete package at working pressure ¹⁾	Dimensions W x D x H	Pressure dew point	Sound pressure level (with ducting) ²⁾	Weight	FAD Complete package at max. overpressure ¹⁾	Dimensions W x D x H	Pressure dew point ³⁾	Sound pressure level (with ducting) ²⁾	Weight
			m ³ /min	mm	°C	dB(A)	kg	m ³ /min	mm	°C	dB(A)	kg
DSG 180-2 RD SFC	110	6	9.5 - 20.8	4270 x 1750 x 2385	-26	78	5250	9.5 - 20.8	4270 x 1750 x 2060	-24	71	4950
		8	8.5 - 18.6		-33			8.5 - 18.6		-32		
		10	9.5 - 16.4		-36			9.5 - 16.4		-36		
		10	9.5 - 16.4		-36			9.5 - 16.4		-36		
DSG 220-2 RD SFC	132	6	8.7 - 22.5	4270 x 1750 x 2385	-25	78	5400	8.7 - 22.5	4270 x 1750 x 2060	-24	72	5100
		8	9.5 - 21.8		-32			9.5 - 21.8		-32		
		10	10.0 - 19.5		-35			10.0 - 19.5		-36		
		10	10.0 - 19.5		-35			10.0 - 19.5		-36		
DSG 260-2 RD SFC	160	6	9.4 - 27.7	4270 x 1750 x 2385	-24	79	5550	9.4 - 27.7	4270 x 1750 x 2060	-24	75	5250
		8	9.6 - 25.4		-31			9.6 - 25.4		-32		
		10	10.3 - 23.3		-34			10.3 - 23.3		-36		
		10	10.3 - 23.3		-34			10.3 - 23.3		-36		
DSG 290-2 RD SFC	200	6	10.3 - 30.0	4270 x 1750 x 2385	-23	81	5700	10.3 - 30.0	4270 x 1750 x 2060	-24	76	5400
		8	11.5 - 30.0		-30			11.5 - 30.0		-32		
		10	12.7 - 28.2		-33			12.7 - 28.2		-36		
		10	12.7 - 28.2		-33			12.7 - 28.2		-36		

Dimensions

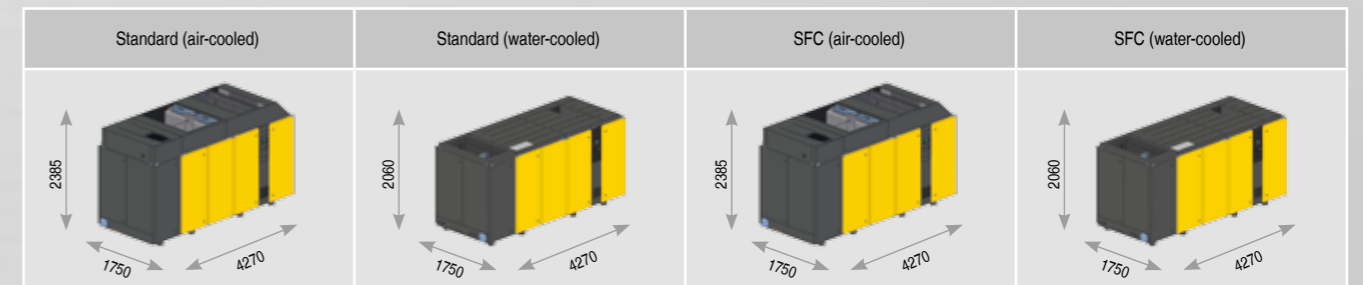

¹⁾ Free air delivery of complete package as per ISO 1217:2009, Annex C: Absolute inlet pressure 1 bar (a), cooling and air inlet temperature 20 °C
²⁾ Sound pressure level as per ISO 2151 and basic standard ISO 9614-2, tolerance: ± 3 dB (A)
³⁾ Pressure dew point at inlet valve 1 bar(a); cooling and air inlet temperature 20 °C; relative humidity 60%; cooling water outlet temperature 30 °C

11 bar-and 5 bar versions available upon request.
 Specifications subject to change without notice

KAESER – The world is our home

As one of the world's largest compressed air systems providers and compressor manufacturers, KAESER KOMPRESSOREN is represented throughout the world by a comprehensive network of branches, subsidiary companies and authorised partners in over 100 countries.

With innovative products and services, KAESER KOMPRESSOREN's experienced consultants and engineers help customers to enhance their competitive edge by working in close partnership to develop progressive system concepts that continuously push the boundaries of performance and compressed air efficiency. Moreover, the decades of knowledge and expertise from this industry-leading system provider are made available to each and every customer via the KAESER group's global computer network.

These advantages, coupled with KAESER's worldwide service organisation, ensure that all products operate at the peak of their performance at all times and provide maximum availability.

